

IPEX-700

A better excimer laser

- **Medium-power excimer lasers** for Industrial, R&D and Scientific applications (including Pulsed Laser Deposition), based on LightMachinery's best-selling high-power IpeX-800 Series industrial excimer lasers
- Now with **exciPure™** technology for ultimate gas lifetimes and lowest cost of operation
- Simple, direct control from a new-generation tablet-based user interface
- User-convenient features, optional air-cooling to 25 Hz, single-phase electrical power, small footprint, single-sided service access, **EasyClean™** automated optics seals to retain gas fill and reduce downtime during optics maintenance
- Excellent beam uniformity, pulse-to-pulse energy stability and short pulse duration
- High-stability optics mounts for ultimate beam pointing accuracy & optional high-brightness optics for applications requiring low beam divergence

IPEX™-740 / 760 Series Excimer Lasers for Industrial & Scientific Applications

IPEX-700 Series lasers are designed for medium-power industrial processing and scientific applications. They deliver versatile performance combined with state-of-the-art industrial reliability.

exciPure™ technology, introduced in 2016, combines improved materials, a new dual-stage filter that removes both particulate and gaseous contaminants, and an improved stabilization algorithm. It represents the greatest improvement in excimer gas lifetime and reduction in operating costs in a generation.

EasyClean™ automated valves filled to the optics ports allow the laser chamber to be sealed and the gas fill to be retained while resonator optics are removed for cleaning and maintenance.

Simple to use

- Advanced tablet-based operator interface
- Optional air cooled operation to 25 Hz
- Premix or individual gas cylinders
- Single phase electrical power
- Integral oil-free vacuum pump
- Single-sided service access and economical to operate

IPEX-700 lasers combine the benefits of high performance with the lowest total cost of ownership and best uptime in the market today.

Optical Beam Delivery Systems

LightMachinery is more than just a laser supplier. With our optical design expertise and together with our integration partners, we can offer complete laser / beam delivery / processing systems for many requirements, including those of PLD customers.

Facilities

<p>Electrical Power Single-phase, 200 – 240 V 50 / 60 Hz</p>	<p>Cooling Optional air cooling up to 25 Hz repetition rates Water cooling at higher repetition rates</p>
<p>Laser Gas Premix or individual gas cylinders Consult LightMachinery for details</p>	<p>Weight (net) 295 kg / 650 lbs.</p>

Dimensions

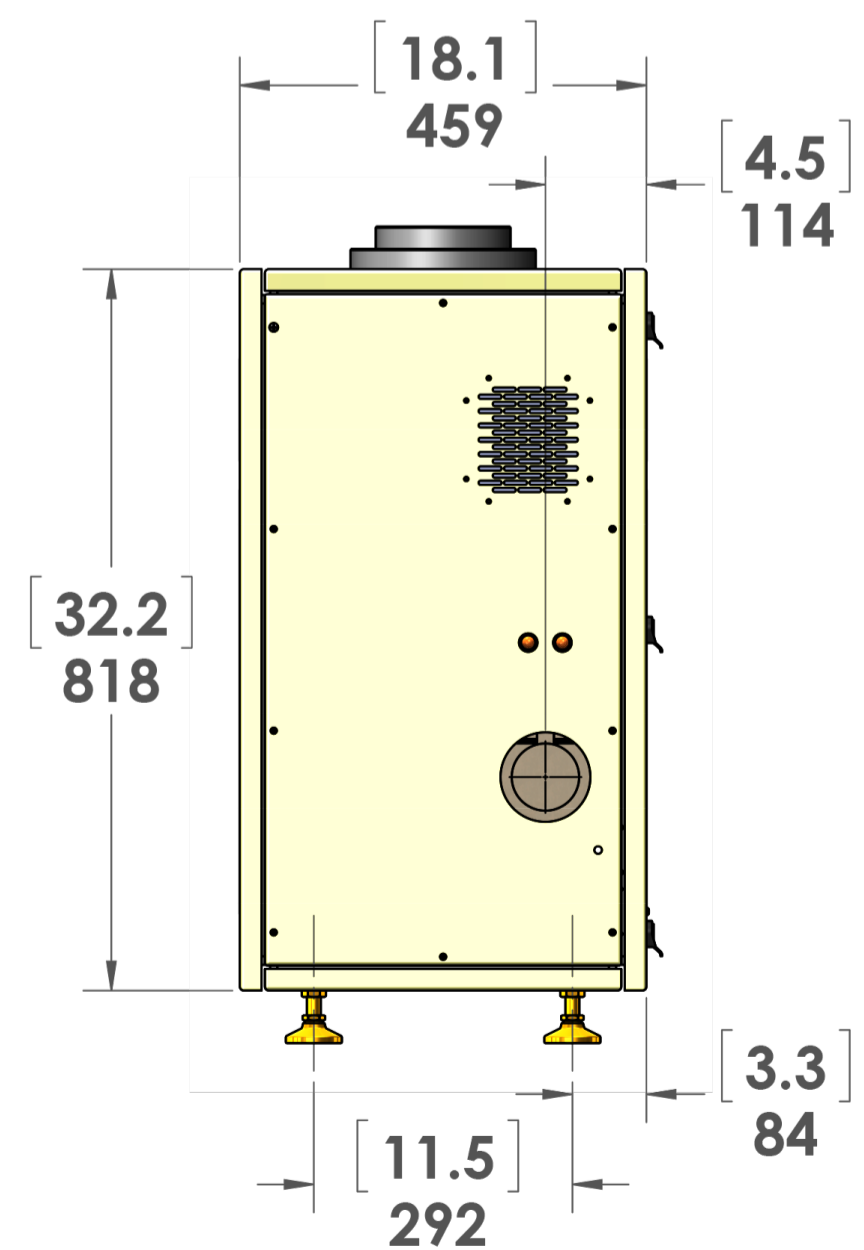
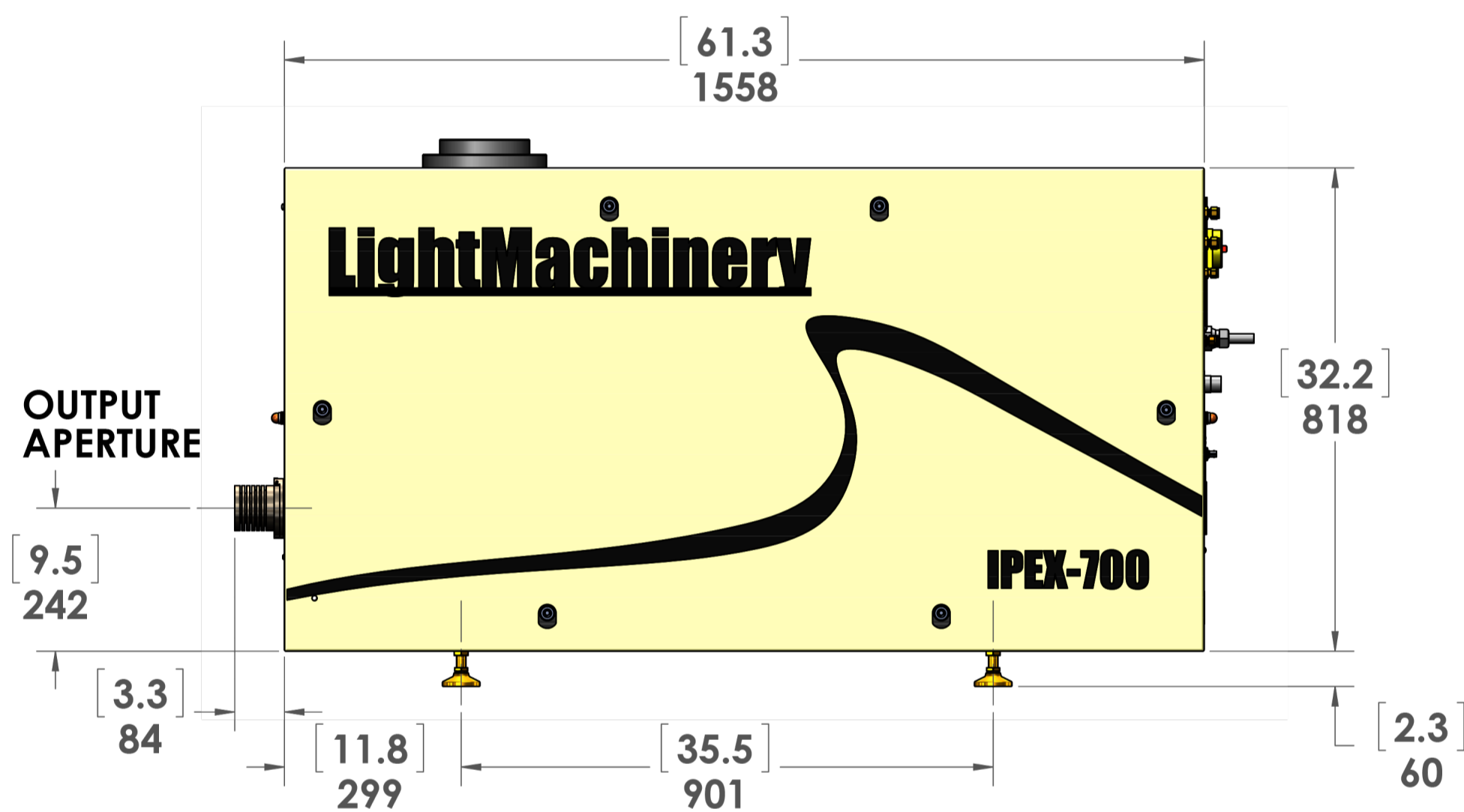

Specifications

	Series	ArF	KrF	XeCl	XeF
Wavelength (nm)		193	248	308	351
Maximum Pulse Energy (mJ) at low repetition rates	IPEX- 740	230	475	300	275
	IPEX- 760	250	700	600	350
Stabilised Pulse Energy (mJ) at maximum repetition rates	IPEX- 740	150	400	250	225
	IPEX- 760	200	600	500	300
Stabilised Average Power (W)	IPEX- 746	15	40	25	22
	IPEX- 744	7.5	20	12	11
	IPEX- 742	3.7	10	6.0	5.5
	IPEX- 766	10	30	25	15
	IPEX- 764	6.0	18	10	9.0
	IPEX- 762	3.0	9.0	5.0	4.5
Maximum Repetition Rate (pps)	IPEX- 746	100	100	100	100
	IPEX- 744	50	50	50	50
	IPEX- 742	25	25	25	25
	IPEX- 766	50	50	50	50
	IPEX- 764	30	30	20	30
	IPEX- 762	15	15	10	15
Pulse Duration (ns) (FWHM)		12-20			
Energy Stability, 1 Sigma (%) (KrF)		1			
Beam Dimensions (mm) (V x H) (nominal)	IPEX- 740	12 x 26			
	IPEX- 760	12 x 28			
Beam Divergence (mrad) (V x H) (nominal) *	IPEX- 740	1 x 3			
	IPEX- 760	1 x 3			

*With standard resonator optics. Can be reduced to ~250 μ rad with High Brightness Unstable Resonator Optics

Specifications are subject to change. Please consult LightMachinery for latest information

For further technical and sales information, please visit our website or contact:

LightMachinery Inc.

80 Colonnade Road

Ottawa, Ontario, Canada, K2E 7L2

lasers@lightmachinery.com

(613) 749-4895